

FINITURE **ESSENZA** / **ESSENZA** FINISHES

Materia viva, certificata, eco-sostenibile. Una proposta unica per varietà, dalle caratteristiche qualitative superiori, senza i difetti tipici del legno tradizionale. Riproducibili nel tempo, per molteplici ambiti applicativi, per superfici orizzontali e verticali. Le finiture PIRARUCU e TARSIE SAND si presentano come metamorfosi di un materiale naturale che attraverso la tecnologia scopre elevate performance ad alto tasso ecosostenibile: dal legno al legno...dalla materia ad una nuova materia che trascende codici sartoriali e tecnologici predefiniti affinché ogni progetto offra nuove declinazioni espressive e personalizzate.

Il modello ESSENZA è realizzabile in tutte le finiture di legno impiallacciato proposte da Vama Cucine.

A living, certified, ecosustainable material. A unique range of offerings, with superior quality characteristics, free of the typical defects of traditional wood, ready to be reproduced over time, for multiple application areas, on horizontal and vertical surfaces. Pirarucu and Tarsie Sand finishes are the metamorphosis of a natural material, which thanks to technology achieves high performance and ecosustainable quality. From wood to wood... from the material to a new material that transcends pre-set codes of workmanship and technology, making every project convey new expressive and customized interpretations.

Essenza model is also available in all VAMA veneer woods selection.

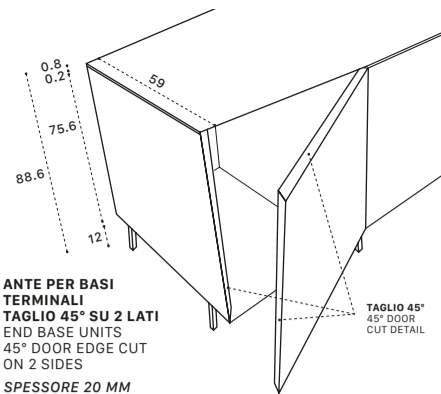
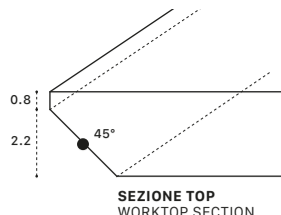

LE COLONNE TERMINALI HANNO SOLO IL LATO ESTERNO A 45°, MENTRE LE COLONNE CENTRALI HANNO TUTTI I LATI QUADRATI (90°)
THE END TALL UNITS HAVE ONLY THE EXTERIOR SIDE WITH 45° CUT. THE CENTRAL TALL UNITS ARE WITH ALL SQUARED EDGES (90°)

ANTE PER BASI TERMINALI TAGLIO 45° SU 2 LATI
END BASE UNITS 45° DOOR EDGE CUT ON 2 SIDES

SPESSORE 20 MM
THICKNESS 20 MM

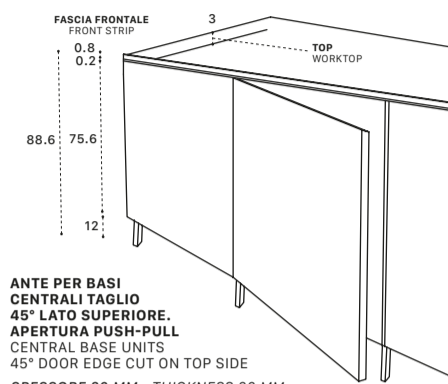

ANTE PER BASI CENTRALI TAGLIO 45° LATO SUPERIORE. APERTURA PUSH-PULL
CENTRAL BASE UNITS 45° DOOR EDGE CUT ON TOP SIDE

SPESSORE 20 MM - THICKNESS 20 MM

FINITURE SPECIALI · SPECIAL FINISHES

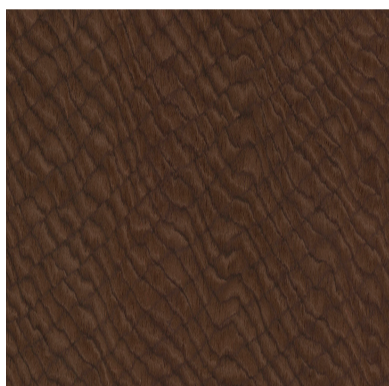

PIRARUCU
PIRACUCU



TARSIE SAND
TARSIE SAND

Pannello in agglomerato di particelle di legno di pino rivestito in tranciato legno.
SPESSORE ANTA: 20 mm

*Panel in poplar wood particles coated with veneer wood.
DOOR THICKNESS: 20 mm*

FASCIA 1
CATEGORY 1

Pannello in agglomerato di particelle di legno di pino rivestito in tranciato legno.
SPESSORE ANTA: 20 mm

*Panel in poplar wood particles coated with veneer wood.
DOOR THICKNESS: 20 mm*

FINITURE DISPONIBILI · AVAILABLE FINISHES



ROVERE
OAK

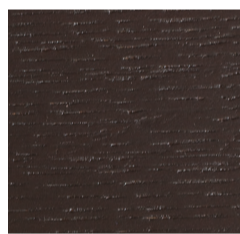

WENGÉ
WENGÉ

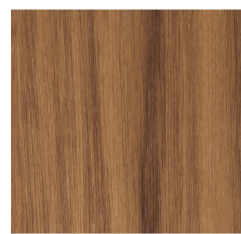

NOCE CANALETTO
CANALETTO WALNUT

FASCIA 2
CATEGORY 2

Pannello in agglomerato di particelle di legno di pino rivestito in tranciato precomposto.
SPESSORE ANTA: 20 mm

*Panel in poplar wood particles coated with reconstituted wood.
DOOR THICKNESS: 20 mm*

FINITURE DISPONIBILI · AVAILABLE FINISHES



TEAK
TEAK

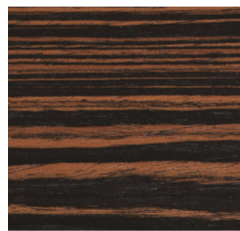

EBANO
EBONY



OLMO
ELM

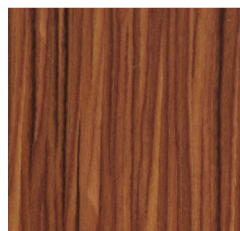

PALISSANDRO FIAMMA
ROSEWOOD

FASCIA 3
CATEGORY 3

Pannello in agglomerato di particelle di legno di pino rivestito in tranciato legno, con effetto segato, nodato e dogato.
SPESSORE ANTA: 20 mm

*Panel in poplar wood particles coated with veneer wood with vertical stripes, wood circles and textured finish.
DOOR THICKNESS: 20 mm*

FINITURE DISPONIBILI · AVAILABLE FINISHES



NOCE
WALNUT

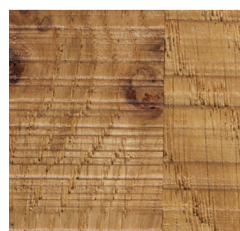

ROVERE
OAK